

SCINTILLATION SPECTROMETER SBL-1 FOR THE X-RAY DENSITOMETER OF RADIOACTIVE TECHNOLOGICAL SOLUTIONS

**M.P. Belousov¹, M.A. Gorbunov², S.V. Dudin¹, O.V. Ignatyev¹,
S.G. Morozov², A.A. Pulin²**

¹*Ural Federal University named after the first President of Russia B.N. Yeltsin
620002, Mira street, 19, Ekaterinburg, Russian Federation
ovi@dpt.ustu.ru*

²*ATOM Electronics Ltd
620041, Uralskaya street, 77/120, Ekaterinburg, Russian Federation*

Received 14 August 2012,
received in revised form 11 December 2012.

Results of property study of the developed high-acting scintillation spectrometer to be used in x-ray densitometer of radioactive solutions with ²⁴¹Am “transmitting” radiant are presented. Fast crystals YAIO₃:Ce (Ø25x0.4 and Ø25x1.0 mm) are used as scintillators. Strong energy resolution dependence of the spectrometer with thin scintillators at crystal illumination (from 16.3 to 20.3 % for a γ -line 59.5 keV) is revealed. The spectrometer input count-rate is over $5 \cdot 10^5$ 1/s, and spectrum accumulation speed is not lower than $2 \cdot 10^5$ 1/s. Due to the conversion gain program stabilization the relative shift and the peak broadening $E_{\gamma} = 59.5$ keV do not exceed 0.25 % and 7.5 %, accordingly.

Keywords: YAIO₃:Ce, x-ray scintillation spectrometer, thin crystal, ²⁴¹Am, radioactive solutions, program stabilization, high count-rate, energy resolution.

Belousov Maxim Pavlovich, a member of the Research Laboratory of Electronics for X-Ray Instruments (RLEXRI) at Institute of Physics and Technology of Ural Federal University.

Field of scientific interests: design of precision scintillation x- and γ -spectrometers.
The author of 6 published papers.

Gorbunov Maxim Aleksandrovich, an engineer of *ATOM Electronics Ltd*, expert in the field of microprocessors, controllers, numeral filtration of detectors signals, printed-circuit board trace.

The author of 2 published papers.

Dudin Sergey Vladimirovich, a member of the Research Laboratory of Electronics for X-Ray Instruments, expert in the field of analogue electronic paths of semiconductor x-ray spectrometers.

The author of 8 published papers and patents.

Ignatyev Oleg Valentinovich, Dr. of Tech. Sci., the head of the Research Laboratory of Electronics for X-Ray Instruments.

Field of scientific interests: research and development in the field of electronics for precision spectrometers with various ionization detectors of x-, γ - and n-radiations.

The author of more than 70 published works, including one monograph and 20 patents, which have found practical application. The winner of the Russian Federation government award in the field of science and engineering.

Morozov Sergey Gennadyevich, the deputy director of *ATOM Electronics Ltd.*, expert in the field of semiconductor and scintillation detection blocks of x- and γ -radiations.

The author of 3 published papers.

Pulin Alexey Aleksandrovich, an engineer of *ATOM Electronics Ltd.*, expert in the field of energy dispersive fluorescent analysis procedures and spectrometers software designer.

The author of 20 published papers.

Introduction

Modern densitometers for industrial radiochemical applications are based on scintillation spectrometers with NaI(Tl) crystal. Radionuclide ²⁴¹Am ($E_\gamma = 59.5$ keV) is frequently used as a source of “transmission” radiation. Densitometric analysis of radioactive solutions sets the following requirements for the spectrometer used in the device:

1. Low detection efficiency for higher energy γ -ray (this is mainly radiation of radionuclide ¹³⁷Cs with energy $E_\gamma = 661.6$ keV). Otherwise Compton continuum from scattering in the detector reduces “contrast” of density measurements. This problem is solved by an appropriate choice of corresponding scintillator thickness.
2. Good resolution on analytical line $E_\gamma = 59.5$ keV reduces the contribution to a statistical error caused by continuous allocation under the analytical peak. In scintillation γ -spectrometers the level of the resolving ability obtained almost completely depends on the detector material properties – light yield (LY) of scintillator measured in a number of light quanta per 1 keV of the absorbed γ -quantum energy and quantum efficiency (QE) of a photomultiplier photocathode. The product of these two values defines the statistical component of the resolution η_{stat} ($LY_{NaI} = 36 \div 38$ ph/keV; $QE = 0.25 \div 0.43$). In the x-ray energy range the light yield of most inorganic scintillators depends on the secondary electron energy [1]. The dependence and inhomogeneity in the crystal lead to the so-called intrinsic resolution η_{intr} , which contribution in the abovementioned energy range is comparable to η_{stat} .
3. While densitometrically measuring radioactive solutions, it is desirable to have the greatest possible activity of a “transmitting” radiant. Radiation resource of a scintillation crystal is therefore to be taken into account. NaI(Tl) crystals in this regard do not seem to be the best choice.

4. Spectrometer fast-action is critical in these applications, since the accuracy of the results depends mainly on it. The most important indicators of fast-action are the maximum input count-rate $R_{i,max}$ and the maximum speed of spectrum accumulation $R_{o,max} \cdot R_{i,max}$ is defined as the maximum count-rate at which the relative broadening $\Delta\eta/\eta$ and shift $\Delta E/E$ of the analytical peak do not exceed the specified values. It is convenient that at $R_i = R_{i,max}$ $\Delta\eta/\eta \leq 10 \div 15\%$ and $\Delta E/E \leq 0.1 \div 0.25\%$. The scintillation spectrometer fast-action is affected by scintillator decay time, gain stabilization system, structure and circuitry of the electronic spectrometer path.

The aim of the present paper is to develop and study scintillation spectrometer count-rate properties with scintillators more perspective than traditional NaI(Tl) ones.

The choice of the scintillator

Over 450 modifications of scintillation materials have been described the literature [2]. However, only about ten of them have the main characteristics not worse than those of classical NaI(Tl) and at least one property of the former is superior to those of the latter. Regarding the fact that not all ten perspective scintillators are employed in industrial production, the choice is unlikely to be rich. We have chosen LaBr₃:Ce (Ø18x3 mm manufactured by our strategic partner – RADICO company, Obninsk, Kaluga region, Russia) as well as YAIO₃:Ce (Ø25x0.4 mm and Ø25x1.0 mm produced by CRYTUR company, the Czech republic). In the world literature YAIO₃:Ce crystals are referred to as YAP:Ce. Table presents comparison of three crystals mentioned above as described in a number of papers.

As the analysis of the data in Table shows, the two crystals we have chosen (LaBr₃:Ce and YAIO₃:Ce) are quite suitable for detecting the line $E_\gamma = 59.5$ keV.

Table

Comparative analysis of three X-ray scintillators

Performance	Scintillator type		
	NaI(Tl)	LaBr ₃ :Ce	YAIO ₃
Specific Gravity r , g/cm ³	3.67	5.10	5.35
Light Yield LY, ph/keV	38	63	≈ 20
Thermal Instability Coefficient of LY, %/°C	- 0.75 in range (-30 ÷ +50) °C [3]	+ 0.01 [4]	+ 0.05 in range (-70 ÷ +125) °C [5]
Decay Time t_{LD} , ns	230	16	27
Wavelength of Max. Emission λ_{max} , nm	415	380	370
Refractive Index n	1.85	≈ 1.90	1.95
Energy Resolution on Lines:			
⁵⁷ Fe $\eta_{14.4 \text{ keV}}$, %	22 [6]	≈ 22.5 [7]	38 [8]
²⁴¹ Am $\eta_{59.5 \text{ keV}}$, %	12÷14 [9]	11.6 [10]	15÷16 [11]; 16.1 [12]
⁵⁷ Co $\eta_{122.1 \text{ keV}}$, %	13 [13]	7 [13]	10.5 [12]

The spectrometer device

The design of scintillation spectrometer SBL-1 is shown schematically on Fig. 1, and the way it looks like is given on Fig. 2. The scintillation crystal sizes have been chosen on the basis of the required dimensions of the spectrometer detecting part and the energy of the γ -line to be recorded ($E_\gamma = 59.5$ keV). The above mentioned as well as the fact, that maximums of their emission spectra are in the range $\lambda_{\max} = 370\text{--}380$ nm define photomultiplier type (PMT) which is HAMAMATSU R3998-100-02 with super bialkali photocathode $\varnothing 25$ mm, providing $QE_{\lambda=350\text{ nm}} = 0.35$ and $QE_{\lambda=400\text{ nm}} = 0.34$.

The spectrometer electronic section is unified as much as possible with the same section of portable-stationary spectrometer STARK-01 [14]. Like all spectrometer channels developed in our study, it contains functional elements apart from linear amplifier (LA) and analog-to-digital converter (ADC). The structure and circuit implementations of the spectrometer electronic section under discussion provide extremely high fast-action and accuracy of the spectrometer. First of all it concerns the "digital" base-line stabilizer (DBLS) [15], realizing Noise Free Additional Pulse Shaping (NFAPS) principle [16, 17]. Fundamental differences of this type stabilizers consist in the fact that they do not introduce count-rate dependent noise [18], base-line stability practically does not depend on amplitudes, shapes and widths T_w of spectrometer pulses up to $DF = R_i \cdot T_w \leq 2$ (dead time up to 200 %). The design principles of pile-up inspector and dead time corrector are such [17] that their performances are coordinated with those of DBLS in terms of the range of amplitudes and maximal input count-rate. High count-rate limitations arise from the photomultiplier tube – the gain change due to the average current flow.

In STARK-01 this problem has been solved by means of light-emitting diode gain stabilization system. When the spectrometer is used as a part of the densitometer with monoline "transmitting" radiation source, the light-emitting diode system appears to be redundant. Due to the rigid fixation of a base-line position in this case, one can employ the algorithm of the program spectrum stabilization. The principle of program stabilization activity comes to the following. While spectrum accumulation being carried out, the analytical peak position (in this case it is a line of ^{241}Am , $E_\gamma = 59.5$ keV) is regularly checked by means of differential spectrum. The given spectrum is calculated as $SP(k \cdot t_c) - SP((k - 1) \cdot t_c)$, where SP is the obtained spectrum, k is a current reading cycle of the spectrometer information in the computer, t_c is an interval between reading cycles. Thus, differential spectrum measuring time is defined as a time interval between readings of the information from the spectrometer and is only $t_c = 500$ ms. It allows one to gain information on change of analytical peak position (APP) without any delay. Differential spectrum processing occurs with each reading of the spectrometer information in the computer (one time per 500 ms). If the information is

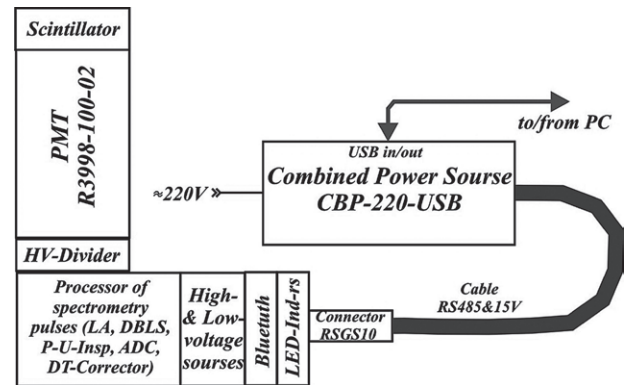

Fig. 1. Structure of x-ray scintillation spectrometer SBL-1

scarce (with count-rate lower than $2 \cdot 10^3$ 1/s), differential spectrum accumulates within several exchange cycles, otherwise APP definition error can make $0.2 \div 0.4$ keV. The normalization coefficient in terms of the previous correction reflects $E_\gamma(n)$ dependence declination change, where n is the number of the spectrometer channel. Initial spectrum normalized by energy is calculated according to the normalization coefficient. Our program correction algorithm of the spectrometer conversion coefficient drift eliminates the necessity in hardware fine adjustment of the amplification constant.

Experimental researches

The study began with YAP:Ce crystals of the sizes mentioned above. The crystals were placed on a thin Al-substrate with mirror surface at the crystal's side. The spectrometer scale calibration was carried out on two lines – 5.89 and 59.5 keV. The fact that the energy resolution $\eta_{59.5\text{ keV}}$ strongly depends on whether

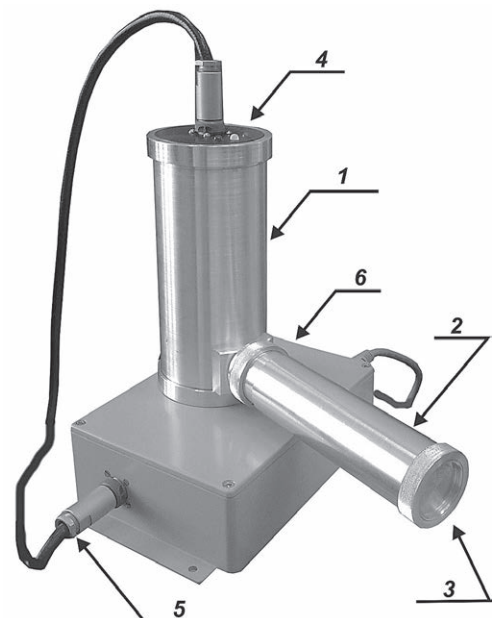

Fig. 2. Appearance of spectrometer SBL-1 with the exterior power supply: 1 - the case of an electronic section; 2 - the case of the PMT with a voltage divider and magnetic protection; 3 - an input window; 4 - light-emitting diode indicators; 5 - the combined communication cable; 6 - the combined power unit (KBP-220-USB)

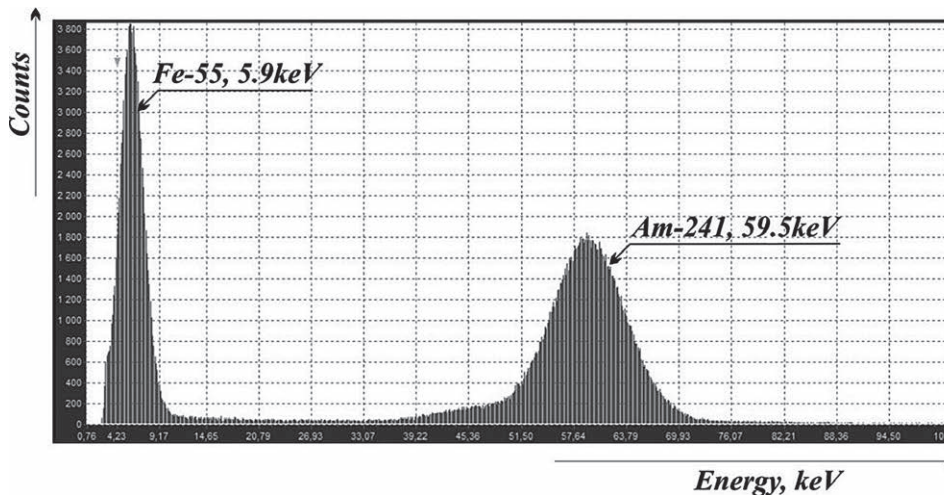

Fig. 3. ⁵⁵Fe + ²⁴¹Am spectrum. Exposure on YAP:Ce Ø25x1.0 mm crystal center through a collimator 3 mm. To the left from the peak $E_\gamma = 59.5\text{keV}$ there is not allowed Y escape peak ($E_\gamma = 59.5 - 14.96\text{keV}$)

a radiant ²⁴¹Am is collimated or not as well as whether it luminesces onto the crystal center or periphery was rather unexpected. Both crystals (Ø25x0.4 mm and Ø25x1.0 mm) showed the same result dependences on illuminating source position - $\eta_{59.5\text{keV}} = 18.3\%$ with the crystal center exposure through collimators Ø1.0mm and Ø3mm; $\eta_{59.5\text{keV}} \leq 20.0\%$ with the exposure at 1/4 of crystal diameter; $\eta_{59.5\text{keV}} \leq 19.9\%$ under conditions of wide geometry (the whole crystal is exposed).

The following procedures were carried out to eliminate this effect:

a) The lateral surface of crystals was wound up with a Teflon film for diffuse reflection. Improvements were not observed.

b) Aluminium substrates of crystals were removed. Measurements were performed with and without diffuse reflector around the crystal lapped to PMT. The diffuse reflector worsened the performances. The best results were obtained without the reflector:

- $\eta_{59.5\text{keV}} = 16.4\%$ at the crystal center exposure;
- $\eta_{59.5\text{keV}} \leq 17.6\%$ with the exposure at 1/4 of crystal diameter;

- $\eta_{59.5\text{keV}} \leq 20.4\%$ under the wide geometry conditions.

In all previous measurements the crystals were lapped to PMT employing optical silicone gel BICRON BC-630 (refractive coefficient $n = 1.42$) to make the change convenient. When the study was completed, crystal YAP:Ce Ø25x1.0 mm was pasted with two-component optical glue SKTN. Test measurements showed some resolution improvement (it is likely to have been caused by high value of glue refractive coefficient):

- $\eta_{59.5\text{keV}} = 16.3\%$ at the crystal center exposure;
- $\eta_{59.5\text{keV}} \leq 16.9\%$ with the exposure at 1/4 of crystal diameter;
- $\eta_{59.5\text{keV}} \leq 20.3\%$ under the wide geometry conditions;
- $\eta_{59.5\text{keV}} \leq 18.2\%$ under the wide geometry conditions after a thin lead collimator with a hole Ø20.0mm had been installed on the crystal.

Fig. 3 shows the measured ⁵⁵Fe + ²⁴¹Am spectrum at the exposure of the crystal Ø25x1.0 mm center. The source ²⁴¹Am luminesced through a steel substrate with ⁵⁵Fe agent, therefore there are no low energy lines of ²⁴¹Am in the spectrum. In the course of the studies interesting properties of PMT HAMAMATSU

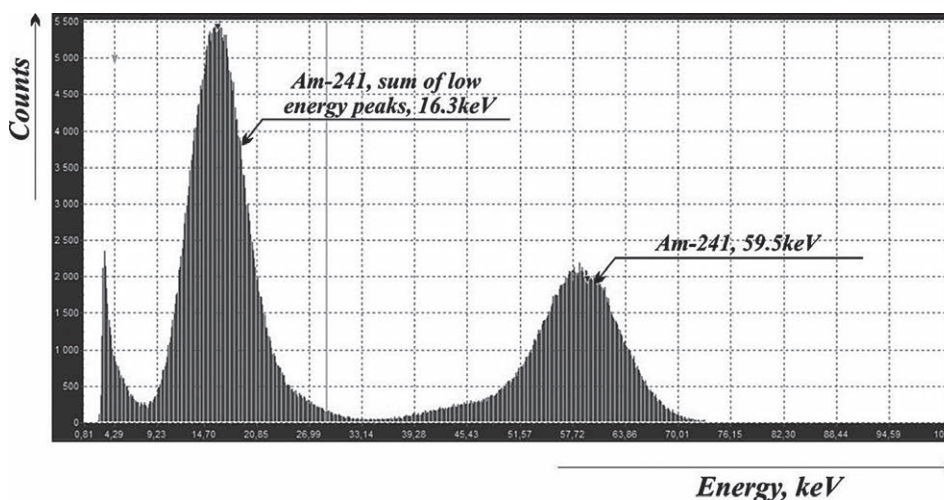

Fig. 4. ²⁴¹Am spectrum. YAP:Ce Ø25x1.0 mm crystal exposure under the “wide geometry” condition with an interior lead collimator Ø20.0 mm. The peak 16.3 keV - the total of not resolved low energy peaks ²⁴¹Am - earlier was killed by a steel substrate

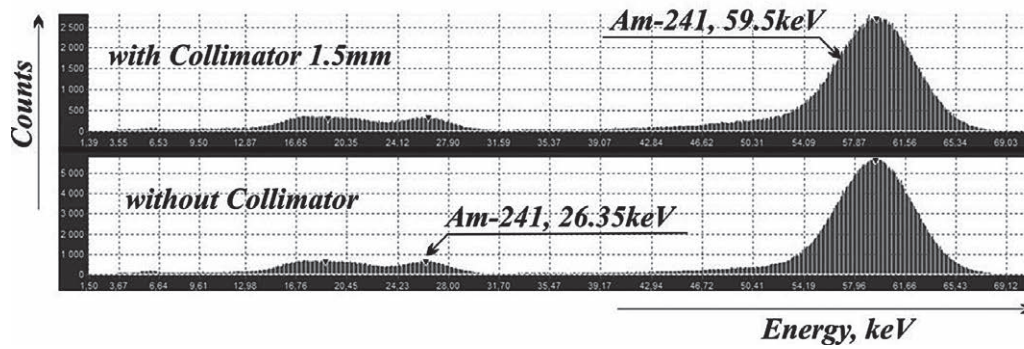

Fig. 5. ²⁴¹Am spectra obtained from LaBr₃:Ce crystal in two “geometries”. The energy resolution practically does not depend on radiation collimation: $\eta_{59.5 \text{ keV}} \leq 11,0 \%$; $\eta_{26.35 \text{ keV}} \leq 14.8 \%$

R3998-100-02 came to light. Use of high voltage (HV) with the value close to that of nominal which is 1000 V gives rise to PMT autoemission. This leads to exponential distribution in the range of energies from zero to 10 keV with intensity up to 125 events per second. As high voltage decreases, intensity and amplitudes of the autoemission pulses drop. At HV = 800 V the mentioned intensity decreases down to 3+5 1/s.

Fig. 4 shows ²⁴¹Am spectrum measured under “wide geometry” condition with interior Pb-collimator Ø20.0 mm.

The series of measurements on LaBr₃:Ce crystal showed that edge effects are not observed in this crystal packed with diffuse mirror unlike in YAP:Ce thin crystals. This is proved by the measured spectra (see Fig. 5). The absence of spatial sensitivity in this case might be caused by lower diameter to thickness ratio. This issue requires further studies.

The resolution considerably better than that of the previous crystals ($\eta_{59.5 \text{ keV}} \leq 11.0 \%$) allows one to resolve peak 26.35 keV. Unfortunately, thick walls of the capsule which contained the scintillator made it impossible to study the spectrometer behavior at the lower energy region.

While experiments being made, the relative light yield of YAP:Ce crystals was measured as well. For this purpose the peak positions of ²⁴¹Am ($E_\gamma = 59.5 \text{ keV}$) were measured in spectrometer SBL-1 adjusted on amplification to operate with LaBr₃:Ce. The peak positions relation expressed in channels was $N_{\text{LaBr}_3} / N_{\text{YAP}} = LY_{\text{LaBr}_3} / LY_{\text{YAP}} = 720 / 76 \sim 9.47$. Such estimation procedure is valid as zero values of the spectrometer scale expressed in energy units and channels practically coincide. If the statistics of the light quanta conversion in the scintillator were the primary resolution factor, energy resolutions would differ from each other by $9.47^{0.5}$, i.e. approximately by 3 times. The measured difference is only $16.3 / 11 \approx 1.48$. It testifies to the smaller contribution of the intrinsic resolution to YAP:Ce crystals in comparison with LaBr₃:Ce crystals which confirms to the data presented in the current literature.

The following can be said concerning high count-rate performances. As it was mentioned earlier, SBL-1 spectrometer electronic section is to the utmost unified

with STARK-01 spectrometer section [14]. Decay times of YAP:Ce and LaBr₃:Ce crystals have the same order of magnitude (see Table). Due to this fact, the above-mentioned spectrometers show almost the same fast-action. The measured microscopic dead time T_D (time required for one event processing at high count-rates) is $T_D = 1.725 \mu\text{s}$ for SBL-1. It guarantees the maximum input count-rate $R_{i, \text{max}} \approx 5.75 \cdot 10^5 \text{ 1/s}$. The maximum count-rate of free amplitude code pile-up is $R_{o, \text{max}} \approx 2.1 \cdot 10^5 \text{ 1/s}$. Such performance can be achieved with NaI(Tl) crystals, but only by incomplete integration of the light flashes [19]. This is equivalent to $\approx 16\%$ decrease of the scintillator light yield, which leads to additional energy resolution degradation. It should be noted that the fast-action limitation of the spectrometer with YAP:Ce-scintillator is not due to the crystal properties, but to the electronic components used.

Conclusion

The designed spectrometer easily meets the requirements to be employed in the specific densitometric installation and can be further improved.

The fast-action achieved in this paper is not ultimate. At YAP:Ce crystal decay time $\tau_{LD} = 27 \text{ ns}$ almost complete integration of the light flashes occurs within $T_{\text{int}} \geq 6.9 \tau_{LD} = 186 \text{ ns}$. If spectrometric pulses with time to maximum (peak time) $T_{\text{peak}} = 200 \text{ ns}$ and the width time $T_w = 600 \text{ ns}$ are formed, as it was done in [20] for diamond detector signal, the spectrometer performance will be characterized by the values of the maximum input count-rate as well as spectra accumulation rate $R_{i, \text{max}} \geq 1.5 \cdot 10^6 \text{ 1/s}$ and $R_{o, \text{max}} \geq 5 \cdot 10^5 \text{ 1/s}$, respectively. The principle of spectrometer electronic channel creation, however, remains unchanged.

Regarding the energy resolution, replacement of thin YAP:Ce crystal by LaBr₃:Ce one undoubtedly leads to the resolution increase (see Fig. 5). The challenge is that the scintillator production technology fails to allow one to reach thickness below 3 mm. This will lead to an almost five-fold increase in γ -radiation background download from ¹³⁷Cs contained in the samples under analysis.

YAP:Ce crystal has one more advantage over other crystals. The price of the former ($\approx 500 \text{ €}$) is quite competitive with that of thin crystal NaI(Tl) currently in

use, whereas vacuum-tight packaging for LaBr₃:Ce crystal makes it rather expensive.

REFERENCES

1. Knoll G.F. Radiation Detection and Measurement (3-rd Edition): John Wiley & Sons, Inc. 2000. 802 p.
2. Scintillation Properties (Modified June 12 2012) / S. Derenzo et [al.] // Lawrence Berkeley National Laboratory, [Electronic resource.]: <http://scintillator.lbl.gov> (Date of the treatment 27.06.2012). 49 p.
3. Temperature behavior of NaI(Tl) scintillation detectors / K.D. Ianakiev et [al.] // Nuclear Instruments and Methods in Physics Research. 2009. V. A 607. P. 432–438.
4. Temperature Dependences of LaBr₃(Ce), LaCl₃(Ce) and NaI(Tl) scintillators / M. Moszynski et [al.] // Nucl. Instrum. and Meth. in Phys. Research. 2006. V. A569. P.739-751.
5. [Electronic resource]: <http://www.crytur.cz/pages/33/scintillation-materials-data/> / site of CRYTUR Company (Date of the treatment 30.06.2012).
6. Intrinsic energy resolution of NaI(Tl) / M. Moszynski et [al.] // Nuclear Instruments and Methods in Physics Research. 2002. V. A 484. P. 259–269.
7. Khodyuk I.V., Dorenbos P. Nonproportional response of LaBr₃:Ce and LaCl₃:Ce scintillators to synchrotron X-ray irradiation // J. Physics Condens. Matter. 2010. V.22. P. 7-19.
8. Mashlan M., Jancik D., Kholmetski A. YAG:Ce and YAP:Ce - Suitable Fast Detectors for Transmission Mossbauer Spectroscopy // Hyperfine Interactions. 2002. V.139/140. P. 673-678.
9. Measurements of NaI(Tl) Electron Response: Comparison of Different Samples / G. Hull et [al.] // IEEE Trans. on Nucl. Sci. 2009. V. NS-26. P. 331-336.
10. A Comparative Study of Silicon Drift Detectors with PMT, Averlanch PD and PIN PD in Gamma Spectrometry with LaBr₃ / M. Moszynski et [al.] // IEEE Trans. on Nucl. Sci. 2009. V. NS-56, №3. P. 1006-1011.
11. Scintillation properties of YAP:Ce / S. Baccaro et [al.] // Nuclear Instruments and Methods. 1995. V. A 361. P. 209-215.
12. Properties of the YAP:Ce scintillator / M. Moszyhski M. et [al.] // Nuclear Instruments and Methods in Physics Research. 1998. V. A 404. P. 157-165.
13. Russo P.A., Vo D.T. Gamma-Ray Detectors for Nondestructive Analysis // Los-Alamos National Laboratory Report LA-UR-05-3813. 2005. 42 p.
14. Portable scintillation gamma spectrometer STARK-01 (Rus) / M.P. Belousov et [al.] // Analytics and the control. 2011. V. 15, № 4. P. 429-438.
15. The stabilizer of a base line of a spectrometer / Ignatyev O. V., Dudin S.V., Pulin A.D.: The patent of Russian Federation RU 2085967 C1; Published 27.07.1997. Bul. № 21. 6 p.
16. Method of magnification of fast-action of spectrometers of an ionizing radiation with semiconductor and other detectors without interior amplification (Rus) / Ignatyev O.V.: The patent of the Russian Federation № 2392642; Published 20.06.2010. Bul. № 17. 15 p.
17. Ignatyev O.V. High count-rate spectrometers with semiconductor detectors of X-ray and gamma radiations (English). The author's abstract Diss ... Dr. of Tech. Sci. S.-Petersburg, 2011. 40 p.
18. Semiconductor detectors in the experimental physics (Rus) / Yu.K. Akimov et [al.] M: Energoatomizdat, 1989. 344 p.
19. Dudin S.V., Ignatyev O.V., Pulin A.D. A fast signal processor for NaI(Tl) detectors // Nucl. Instrum. and Meth. in Phys. Research. 1995. V. A 352. P. 610-613
20. Ignatyev O.V., Pulin A.D. A high count-rate spectroscopy amplifier // Nucl. Instrum. and Meth. in Phys. Research. 2004. V. A 516. P. 160-166..